

Apprenticeship Math 12
ASSIGNMENT: Volume Review

Name: _____

Date: _____

Round your answers to the nearest hundredth. Don't forget to include units!

1. What is the volume of the box shown, to the nearest cubic centimeter?

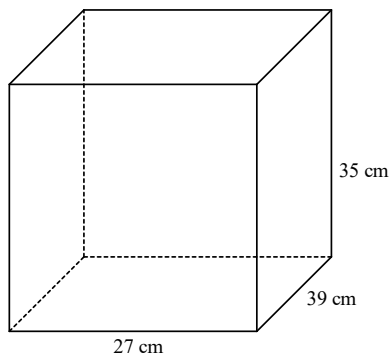

2. A parade includes a large spherical balloon. What is the volume of the balloon if it has a radius of 25 feet?

3. What is the volume of this pyramid?

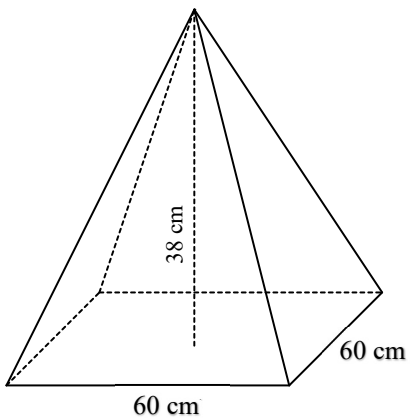

4. A farmer's cylindrical silo has a radius of 1.5 m and is filled with grain to a height of 7 m. He is using the grain to fill rectangular crates that are each 30 cm by 50 cm by 70 cm. How many crates will he be able to fill completely full?

5. What is the volume of a cone with radius of 50 cm and a slant height of 75 cm?

6. What is the volume of the figure below?

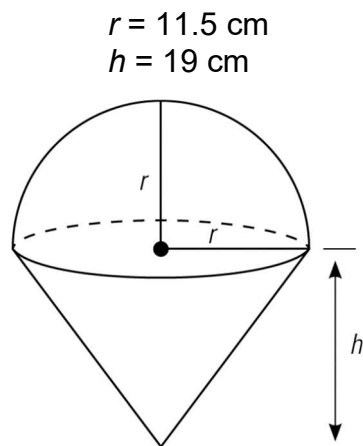

7. If a cylinder had a radius of 7 cm and a volume of 3000 cm^3 what is the height of the cylinder?

8. A delicate glass tube is being delivered to a school science lab. The tube is 60 cm long with a radius of 0.75 cm. It is being shipped in a cylindrical container with a length of 70 cm and a radius of 2.25 cm.

- a) Determine the volume of the glass tube, to the nearest hundredth.

- b) Determine the volume of the shipping container, to the nearest hundredth.

- c) Calculate the amount of sawdust, in liters, required to fill the area between the shipping container and the glass tube. Round your answer to the nearest tenth. (Hint: $1 \text{ L} = 1000 \text{ cm}^3$)

1. 36 855 cm³
2. 65 449.85 ft³
3. 45 600 cm³
4. 471 full crates
5. 146 351.09 cm³
6. 5816.66 cm³
7. 19.49 cm
8. a) 106.03 cm³, b) 1113.30 cm³, c) 1.0 L